

Eclipse ThermAir

Burners

Model TA0040

Version 2

Parameter		Specification	
		Packaged Blower Size	
Maximum Input, BTU/hr (kW)^{1 2} <i>(To maintain 15% air with the standard air orifice and standard combustion air blower.)</i>	Chamber Pressure "w.c. (mbar)	3" w.c. (60 Hz)	6" w.c. (Nominal 50 & 60 Hz)
	-1.0 (-2,5)	403,000 (118)	467,000 (137)
	0.0 (0,0)	375,000 (110)	400,000 (117)
	1.0 (2,5)	345,000 (101)	370,000 (108)
Minimum Input, BTU/hr (kW)		8,000 (2,3)	13,000 (3,8)
Main Gas Inlet Pressure, "w.c. (mbar)³ <i>Fuel pressure in gas inlet (Tap B)</i>		7.7 (19,2)	
High Fire Flame Length, inches (mm) <i>Measured from outlet end of combustor</i>	Natural Gas	35 (889)	
	Propane	39 (991)	
	Butane	39 (991)	
Maximum Application Temperture, °F (°C) <i>Note: For higher temperatures contact Eclipse.</i>	Alloy Tube	1500 (820)	
	SiC Tube	1900 (1040)	
Flame Detection		Flamerod or UV Scanner	
Fuel⁴ <i>For any other mixed gases, contact Eclipse.</i>		Natural gas, propane, or butane	
Blower Motor Power		3" w.c. @ 4600 scfh, 0.167 hp	6" w.c. @ 5500 scfh, 0.25 hp
Weight, lbs (kg)⁵	With Blower	110 (50)	
	Without Blower	64 (24)	
Approvals		 AI30	

- Maximum inputs are given for the standard packaged combustion air blower without an air filter.
- Blower motor service factors greater than 1.0 may be required when firing into negative chamber pressure applications. For specific application questions, contact Eclipse.
- For proper performance, this pressure must be kept constant across the burner operating range.
- See Design Guide 114 for more information about typical fuel composition and properties.
- All weights are approximate.
 - All information based on laboratory testing in neutral (0.0" w.c.) chamber with standard combustion design. Different chamber conditions and/or combustor design will affect the data.
 - All inputs are based upon gross calorific values and standard conditions: 1 atmosphere, 70°F (21°C).
 - Eclipse reserves the right to change the construction and/or configuration of our products at any time without being obliged to adjust earlier supplies accordingly.

Performance Graphs

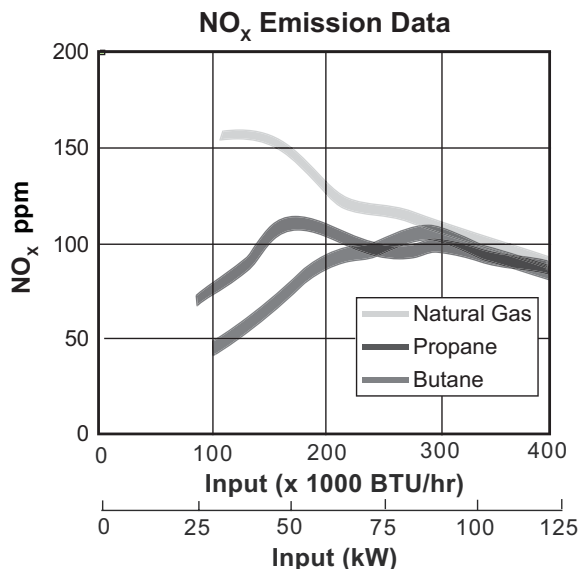
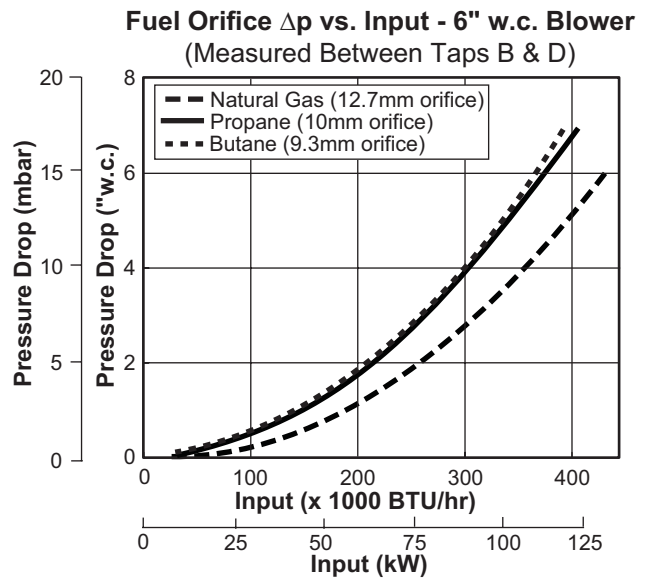
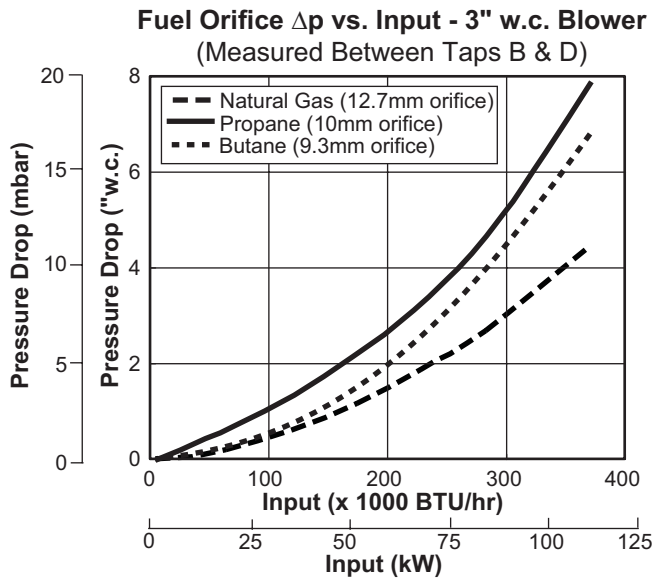
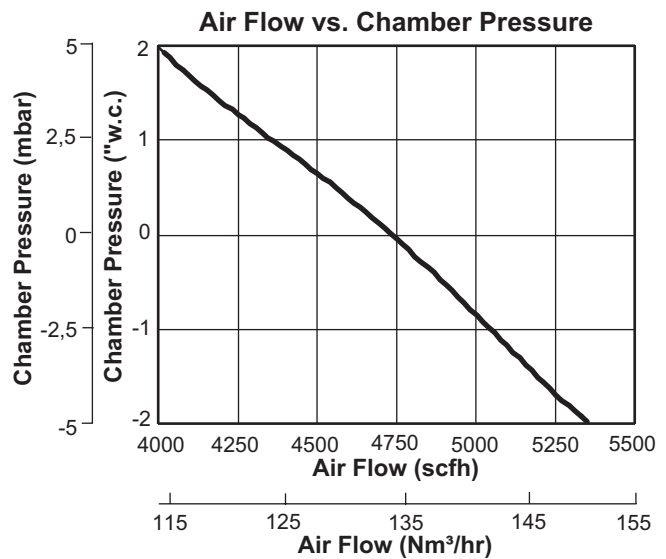
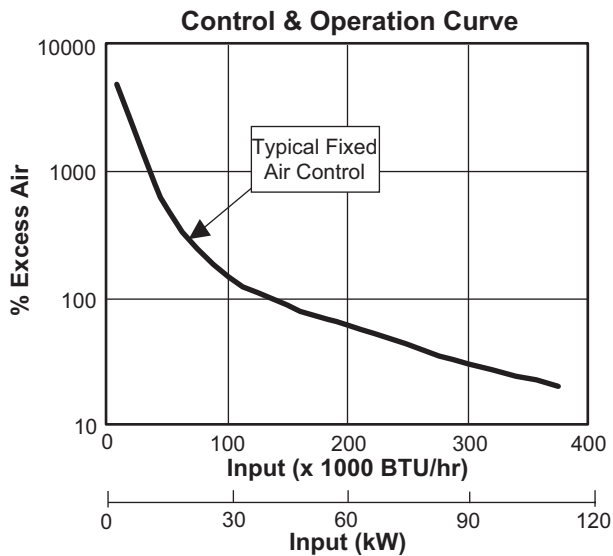

NO_x emission data is given for:

- Ambient combustion air ~70°F (20°C)
- Minimal process air velocity
- ppm volume dry at 3% O₂
- Neutral chamber pressure

Emissions are influenced by:

- Chamber conditions
- Fuel type
- Firing rate
- Ratio regulator adjustment
- Combustion air temperature

CO emission is largely influenced by chamber conditions. Contact your local Eclipse representative for an estimate of CO emission on your application.

Dimensions mm (inches)

Blower	EE	FF	GG	HH
60 Hz (6" wc)	503 (19.8)	410 (16.1)	400 (15.7)	374 (14.7)
50 Hz (6" wc)	567 (22.3)	474 (18.7)	453 (17.8)	427 (16.8)

Combustor Type	JJ	KK
Straight Alloy Tube	84.7 (3.33)	88.9 (3.5)
Straight Silicon Tube	84.3 (3.32)	93.3 (3.67)

Packaged Blower

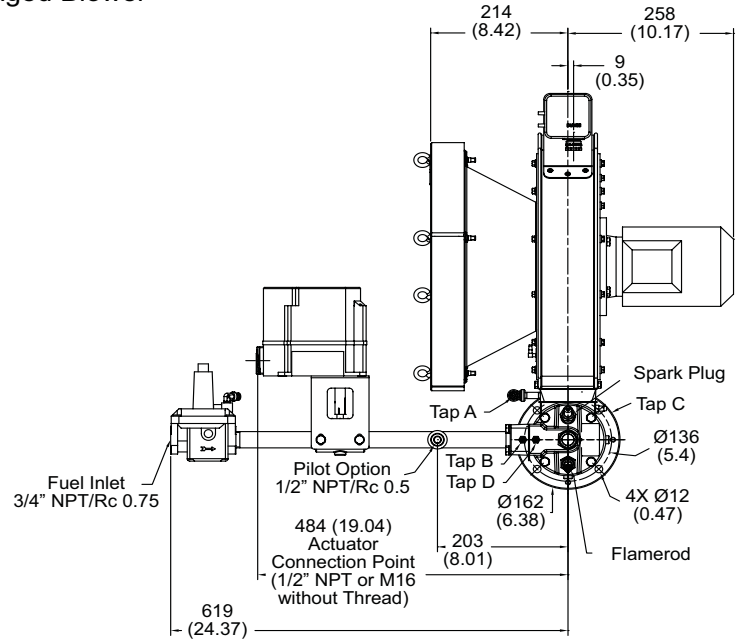
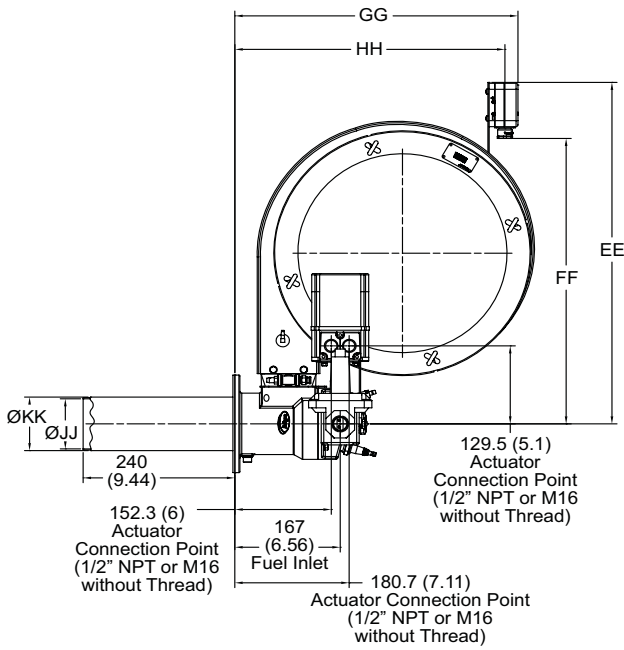

Remote Blower

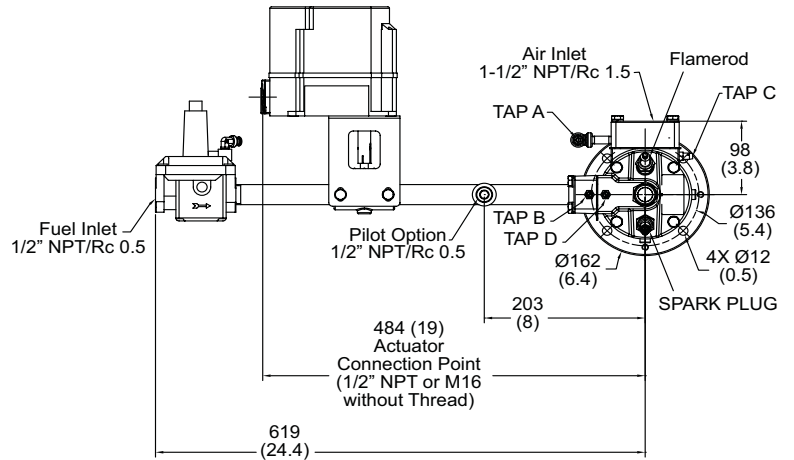
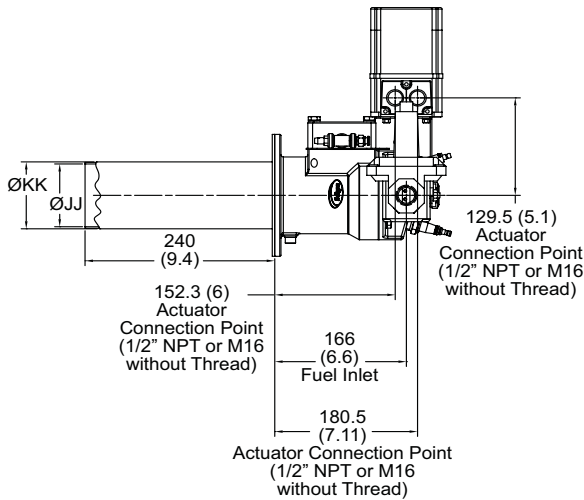

Piping

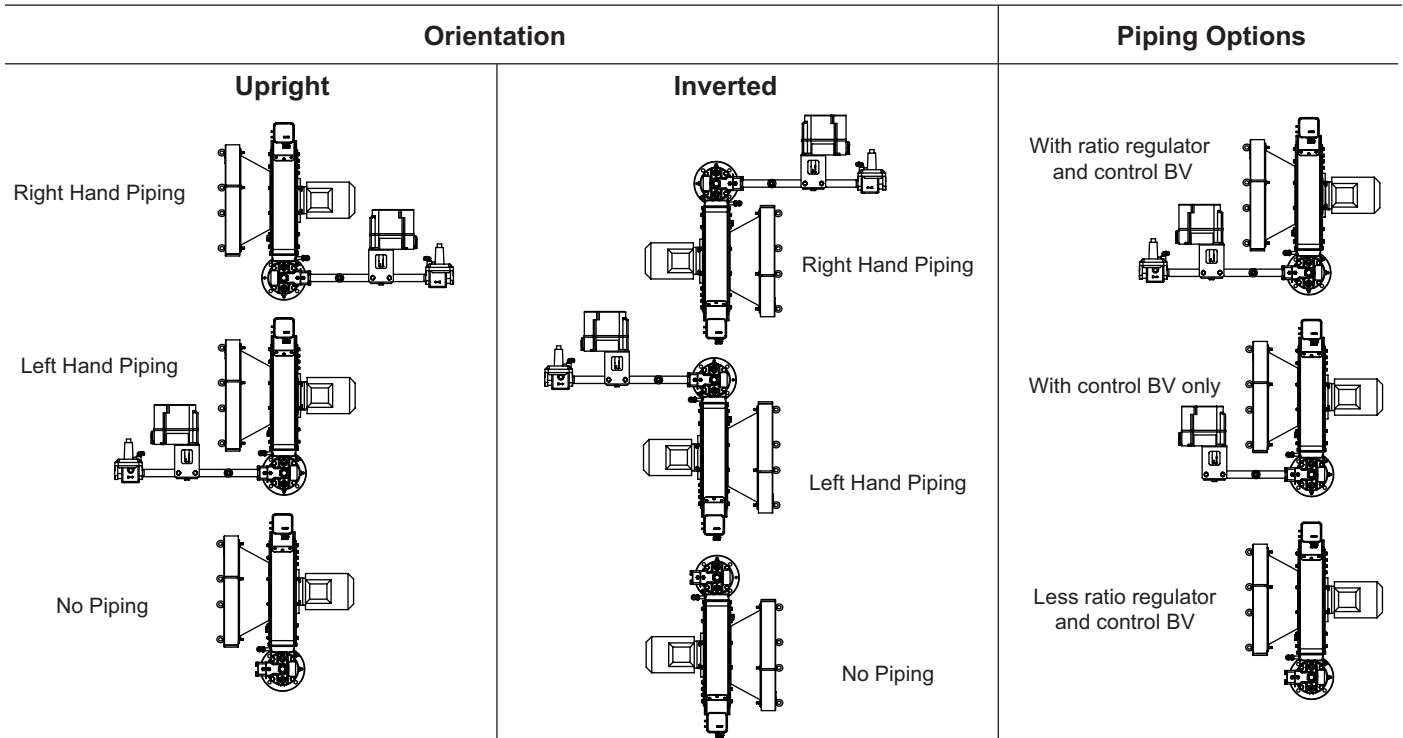

Ratio regulator not available for
3" w.c. packaged version



Offered By:

Power Equipment Company
2011 Williamsburg Road
Richmond, Virginia 23231
Phone (804) 236-3800
Fax (804) 236-3882

www.peconet.com